

Vent-Axia®

Simply Quiet Exhaust Fan Range

Installation and Wiring Instructions



VASF125B -	495812
VASF125T -	495813
VASF125HT -	495814
VASF150B -	495815
VASF150T -	495816
VASF150HT -	495817

PLEASE READ INSTRUCTIONS IN CONJUNCTION WITH ILLUSTRATIONS.
PLEASE SAVE THESE INSTRUCTIONS.

IPX4

Installation and Wiring Instructions for the Simply Quiet Range of Exhaust Fans.



IMPORTANT: READ THESE INSTRUCTIONS BEFORE COMMENCING THE INSTALLATION

DO NOT install this product in areas where the following may be present or occur:

- Excessive oil or a grease laden atmosphere.
- Corrosive or flammable gases, liquids or vapours.
- Ambient temperatures higher than 40°C or less than -5°C.
- Possible obstructions which would hinder the access or removal of the Fan.

SAFETY AND GUIDANCE NOTES

- A.** All wiring to be in accordance with the current I.E.E. Regulations, or the appropriate standards of your country and **MUST** be installed by a suitably qualified person.
- B.** The Fan should be provided with a local isolator switch capable of disconnecting all poles, having a contact separation of at least 3mm.
- C.** Ensure that the mains supply (Voltage, Frequency, and Phase) complies with the rating label.
- D.** The Fan should only be used in conjunction with the appropriate Vent-Axia products.
- E.** The Fan should only be used in conjunction with fixed wiring.
- F.** When the Fan is used to remove air from a room containing a fuel-burning appliance, ensure that the air replacement is adequate for both the fan and the fuel-burning appliance.
- G.** The Fan should not be used where it is liable to be subject to direct water spray for prolonged periods of time.
- H.** Where ducted Fans are used to handle moisture-laden air, a condensation trap should be fitted. Horizontal ducts should be arranged to slope slightly downwards away from the Fan.
- I.** This appliance is not intended for use by persons (including children) with reduced physical, sensory or mental capabilities, or lack of experience and knowledge, unless they have been given supervision or instruction concerning use of the appliance by a person responsible for their safety.

- J.** Children should be supervised to ensure that they do not play with the appliance.
- K.** Stationary appliances not fitted with means for disconnection from the supply mains having a contact separation in all poles that provide full disconnection under over voltage category III, the instructions state that means for disconnection must be incorporated in the fixed wiring in accordance with the wiring rules.
- L.** Ensure the grille is fully engaged onto the fan chassis using the 2 clips.

DESCRIPTION

VASF125 & VASF150 axial exhaust fans are suitable for domestic bathrooms, W.C's. domestic kitchens and utility rooms. They are available as wall or panel/ceiling mounted models with shutter, timer, humidity combinations.

INSTALLATION

IMPORTANT: The fan should only be used in conjunction with fixed wiring.

PANEL/CEILING MOUNTING

1. For panel/ceiling mounting the fan should be installed into a duct protected by an exterior air grille that must comply with the standard requirements of your country to prevent access to the fan's impeller.
2. Cut a 130mm hole for 125mm fans or a 155mm diameter hole for 150mm fans.
3. Push the two clips on the left and righthand side of the fan and pull the grille away from the chassis.
4. Using the built in spirit level bubble as an aid, mark the screw centres through the holes in the fan back plate. Drill, plug and screw into position.
5. After installation, ensure impeller rotates freely and the shutters can open.
6. Replace the grille and ensure the clips engaged.

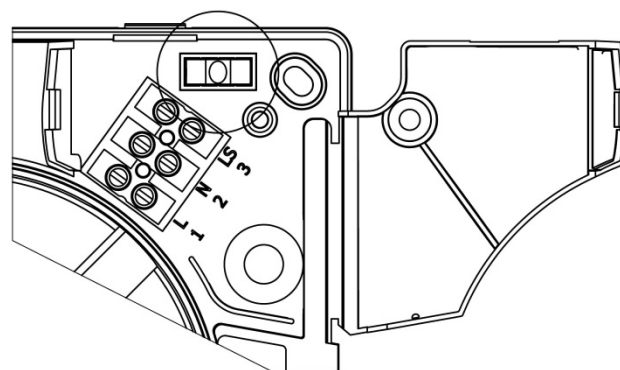
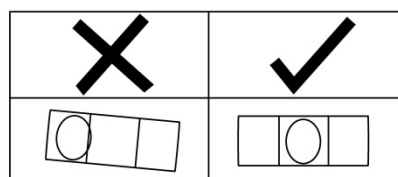

Open up the internal cover to access the spirit level bubble and terminals

WALL MOUNTING

1. For wall mounting either cut a 140mm hole for 125mm fans or a 170mm diameter hole for 150mm fans, through the wall and insert the wall sleeve. Slope the sleeve slightly downwards away from the fan. Cut to length and cement both ends into position flush with the wall faces.
2. Push the two clips on the left and righthand side of the fan and pull the grille away from the chassis.
3. Using the built in spirit level bubble as an aid, mark the screw centres through the holes in the fan back plate. Drill, plug and screw into position. Fix exterior grille into position with the louvres positioned downwards. (Note:- The grille must comply with the standard requirements of your country to prevent access to the fan's impeller. The wall kit used in this installation should

provide a minimum ducting length of 100mm from the fans back plate to the inside of the external grille).

4. After installation, ensure impeller rotates freely and the shutters can open.
5. Replace the grille and ensure the clips engaged.

WIRING



WARNING: THE FAN AND ANCILLARY CONTROL EQUIPMENT MUST BE ISOLATED FROM THE POWER SUPPLY DURING THE INSTALLATION / OR MAINTENANCE.

IMPORTANT

- The fan should only be used in conjunction with fixed wiring.
- The cross - sectional area of supply cord used should be ranged from 1 -1.5mm².
- Cable entry can only be made from the rear of the fan.
- The extraction fan is suitable for connection to 220-240V 50Hz supply.
- The fan is a class II double insulated product and **MUST NOT** be earthed.

1. Select and follow the appropriate wiring diagram. (Fig. 1,2 or 3)
2. Check all connections have been made correctly and securely fastened.
3. Ensure the impeller rotates and is free from obstructions.

SETUP



WARNING: THE FAN AND ANCILLARY CONTROL EQUIPMENT MUST BE ISOLATED FROM THE POWER SUPPLY DURING THE INSTALLATION / OR MAINTENANCE.

VASF125B/150B

Single speed fan. Controlled by remote switch (e.g. light switch or auto sensor) Fig.1.

VASF125T/150T

Single speed with overrun timer*. The fan can be wired to a lighting circuit switch. Fig.3. or wired for a basic on/off operation wire as Fig 2.

When switched 'ON', the fan will operate at full speed and will continue to run for a pre-set time after the switch is turned 'OFF'.

TIMER ADJUSTMENT

BEFORE ADJUSTING THE TIMER, SWITCH OFF THE MAINS SUPPLY. TIMER SHOULD ONLY BE ADJUSTED BEFORE OR DURING INSTALLATION.

1. Remove the fan grille. The controller is factory set at 15 minutes approx. The overrun time period can be adjusted from 5-30 minutes by altering the adjuster on the control PCB. Note the exact min/max time may vary between products.
2. To REDUCE the operating time, use a small screwdriver to turn the adjuster Fig.4. ANTI-CLOCKWISE.
3. To INCREASE the operating time, use a small screwdriver to turn the adjuster Fig.4. CLOCKWISE.
4. Replace the fan grille.

VASF125HT/150HT

Humidity Timer* - Humidity controlled with fixed 15min. timer overrun. Variable speed options selectable at install. See Fig 5.

1. Remove the fan grille. The controller is factory set at 15 minutes approx. JP1 fitted.
2. Select variable speed setting required Fig 5.
3. Select comfort setting if required. Default off. Fig 5.
4. Replace the fan grille.

Ambient Response Humidity Function

The inbuilt humidity sensor automatically adjusts dependant on ambient conditions and does not need adjusting.

Speed Selection

Adjust the fan speed by turning the pot clockwise to increase, and anti-clockwise to decrease

Timer Function (JP1)

JP1 to deactivate the timer, remove the jumper. 15min. timer = jumper in. No timer = jumper out

Comfort mode (JP2)

JP2 should be connected to enable comfort mode. (default off). This feature delays the LS input boost operation for a maximum of 20 minutes to reduce noise and cold drafts while bathing. After the LS is disconnected, the fan will switch on for the same period the LS had been active (up to 20 minutes), plus the overrun time period if selected (0 or 15 minutes).

***All timer versions require a third switch live wire for the timer to work.**

SERVICING AND MAINTENANCE



WARNING: THE FAN AND ANCILLARY CONTROL EQUIPMENT MUST BE ISOLATED FROM THE POWER SUPPLY DURING MAINTENANCE.

1. At intervals appropriate to the installation, the fan should be inspected and cleaned to ensure there is no build up of dirt or other deposits.
2. Wipe the inlets and front face with a damp cloth until clean.

The fan has sealed for life bearings, which do not require lubrication.

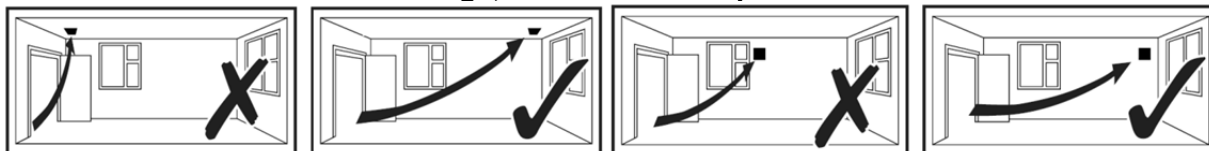

Fig.1: VASF125B/150B

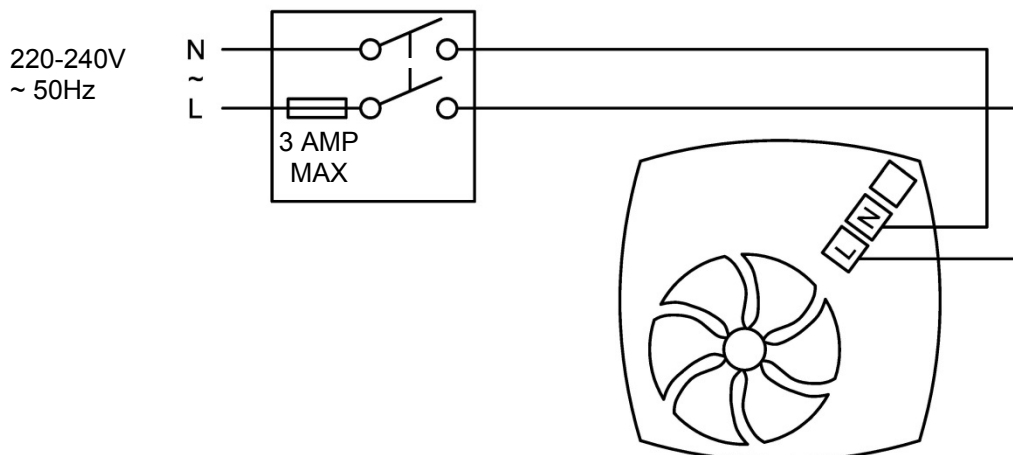

Fig.2: VASF125T/150T & VASF125HT/150HT (Timer /Humidistat disabled)

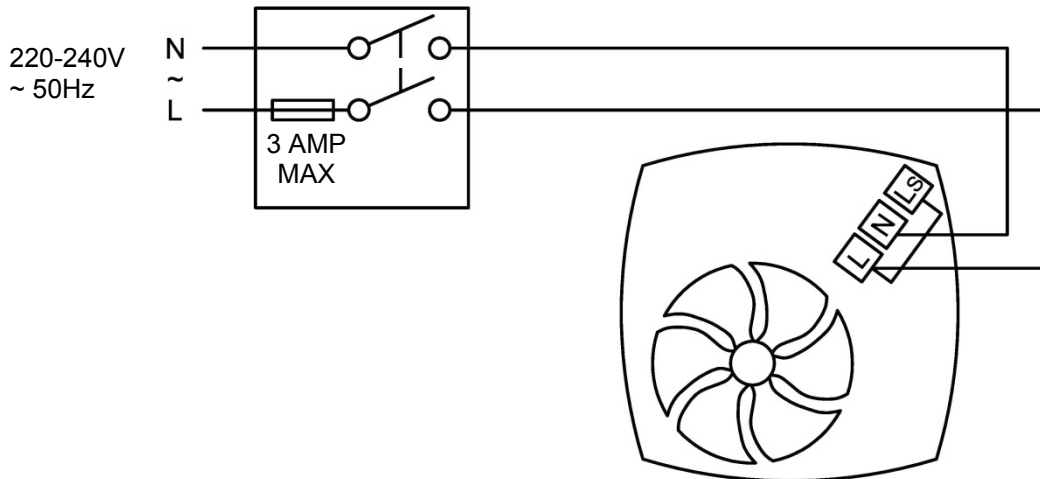

Fig.3: VASF125T/150T & VASF125HT/150HT

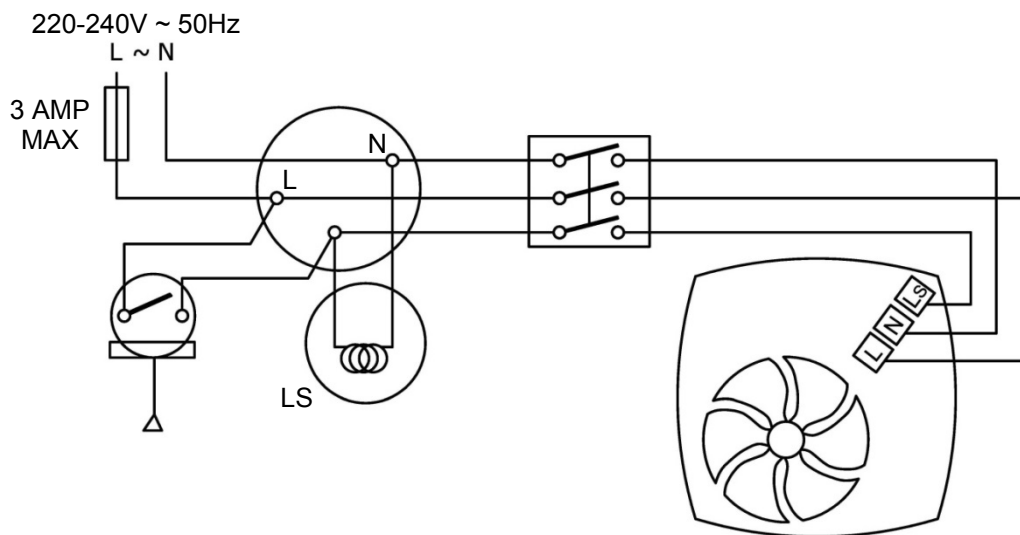
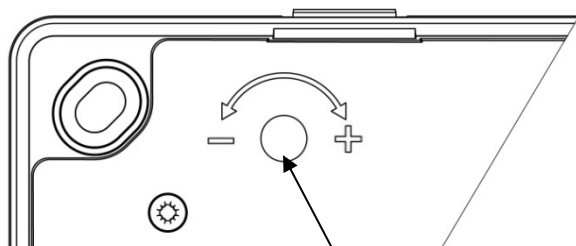

FIG. 4: TIMER



Timer Adjustment

Timer Adjustment

To **REDUCE** the operating time, use a small screwdriver to turn the adjuster **ANTI-CLOCKWISE**.
To **INCREASE** the operating time, use a small screwdriver to turn the adjuster **CLOCKWISE**.

Fig.5: VASF125HT, VASF150HT

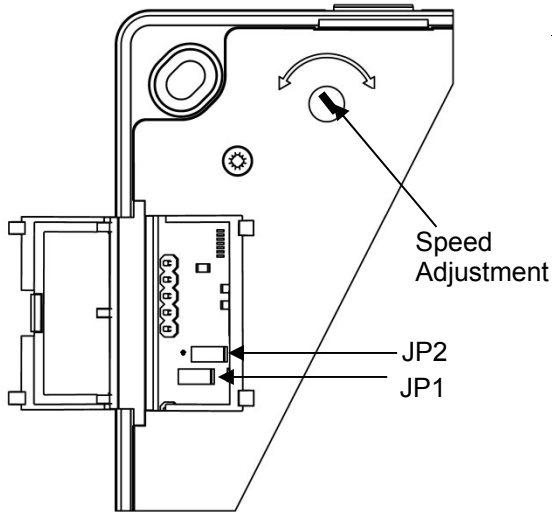

Ambient Response Humidity Function

The inbuilt humidity sensor automatically adjusts dependant on ambient conditions and does not need adjusting.

Speed Selection

Adjust the fan speed by turning the pot clockwise to increase, and anti-clockwise to decrease.

Comfort mode (JP2)

JP2 should be connected to enable comfort mode. (default off). This feature delays the LS input boost operation for a maximum of 20 minutes to reduce noise and cold drafts while bathing. After the LS is disconnected, the fan will switch on for the same period the LS had been active (up to 20 minutes), plus the overrun time period if selected (0 or 15 minutes).

Timer Function (JP1)

JP1 to deactivate the timer, remove the jumper.
15min. timer = jumper in.
No timer = jumper out.



Disposal

This product should not be disposed of with household waste. Please recycle where facilities exist. Check with your local authority for recycling advice

Vent-Axia®

Vent-Axia Australia
4 Capital Place,
Carrum Downs,
Victoria, 3201